



# INSTALLATION INSTRUCTIONS

Accessory  
**REAR UNDER SPOILERS**

Application  
**2010 INSIGHT**

Publications No.  
**All 41265**

Issue Date  
**MARCH 2009**

## PARTS LIST

Left rear under spoiler

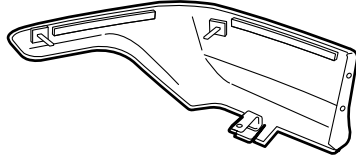

Right rear under spoiler

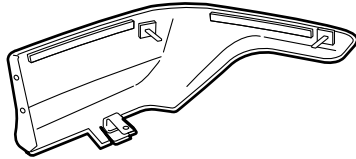

Template

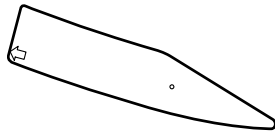

Template A

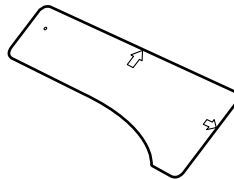

Template B

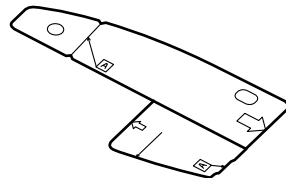

2 Flange bolts

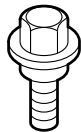

2 Clip nuts



4 Self-tapping screws



2 Spring nuts



20 Seals

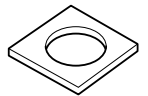

4 Clips



## TOOLS AND SUPPLIES REQUIRED

Phillips screwdriver

Ratchet

10 mm Socket

Drill

3 mm and 10 mm Drill bits

Plastic trim tool

T/N SILTRIMTL 10

Shop towel

Masking tape

File

Scissors

Pushpin

Isopropyl alcohol

Felt-tip pen

Eye protection (safety goggles, face shield, etc.)

Hex wrench

12 mm Hole saw

Diagonal cutters

Blanket

Rubber roller

T/N MHLE54D

**Illustration of the Rear Under Spoilers Installed on the Vehicle**

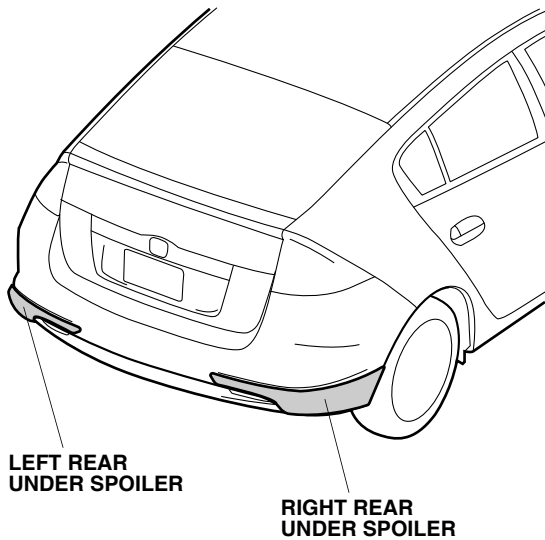

**INSTALLATION**

**Customer Information:** The information in this installation instruction is intended for use only by skilled technicians who have the proper tools, equipment, and training to correctly and safely add equipment to your vehicle. These procedures should not be attempted by “do-it-yourselfers.”

**NOTE:**

- Do not damage the body paint finish.
- This rear under spoiler kit should only be installed if the ambient air temperature is 15°C (60°F) or above.
- To allow the adhesive to cure, do not wash the vehicle for 24 hours. Please advise the customer.

1. Remove the rear bumper:
  - Remove the four clips, the six screws, the four hex bolts, and the two self-tapping screws.
  - With the help of an assistant, carefully pull the bumper out to release the 12 retaining tabs (six on each side).
  - Place the rear bumper on a blanket to prevent damage.

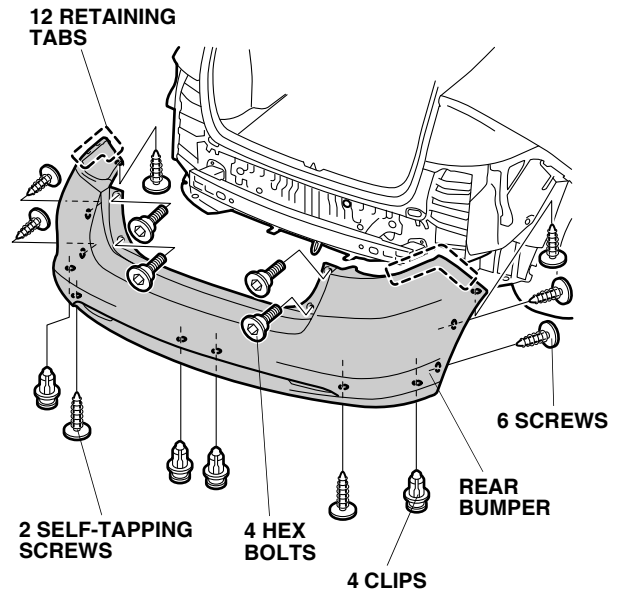

- On the inside of the rear bumper on the left side, tape template A to the bumper in the area shown.

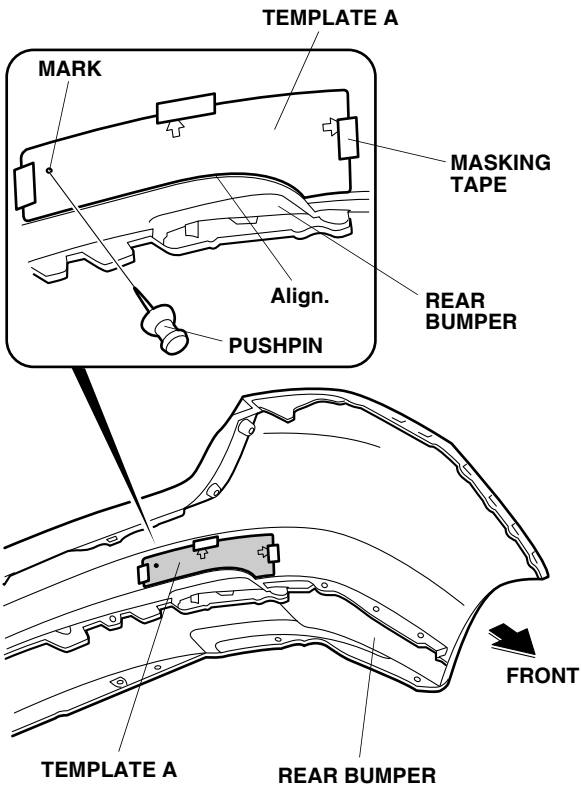

- Using a pushpin, pierce a hole through the bumper at the mark on the template. Remove the template.

- While wearing eye protection, drill the bumper:
  - From the painted surface of the bumper drill a 3 mm hole at the pierced mark.
  - Using a 12 mm hole saw, enlarge the 3 mm hole to 12 mm.
  - Remove all burrs.

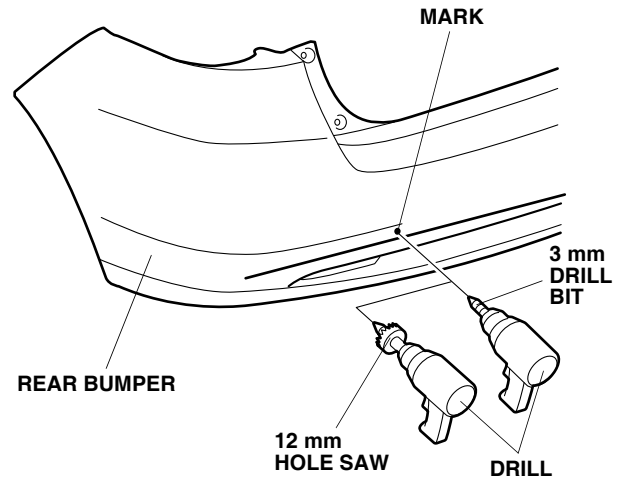

- On the inside of the rear bumper on the left side, tape the template to the inside edge in the area shown.

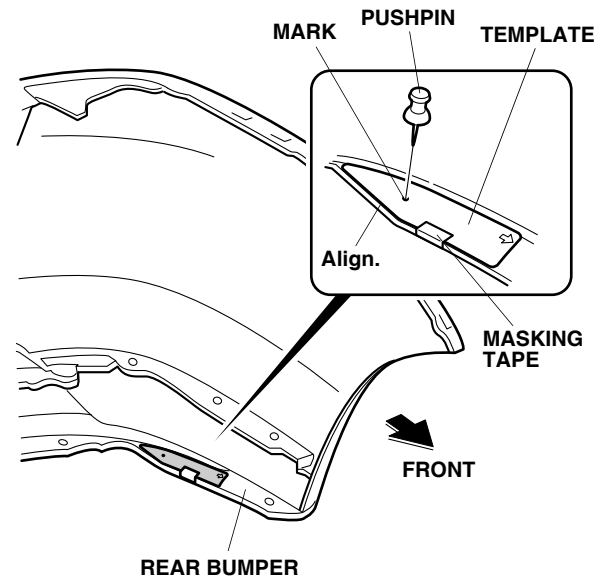

- Using a pushpin, pierce a hole through the bumper at the mark in the template. Remove the template.

7. Turn the bumper over. While wearing eye protection, drill the bumper:
  - From the painted surface of the bumper, drill a 3 mm hole at the pierced mark.
  - Using a 10 mm drill bit, enlarge the 3 mm hole to 10 mm.
  - Remove all burrs.

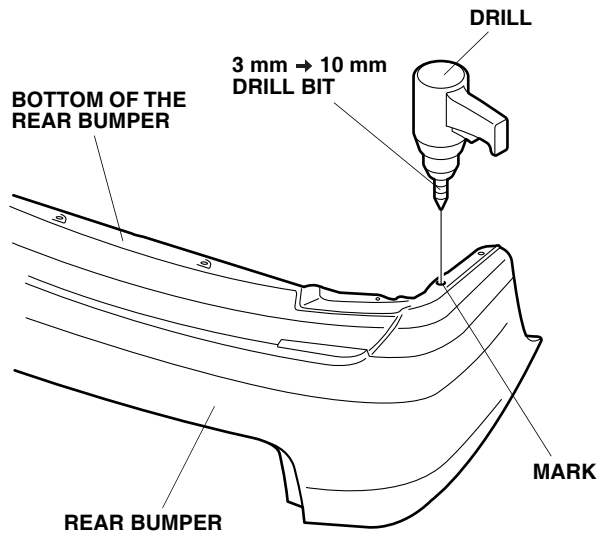

8. Get template B. Using scissors, cut template B to remove the small portion of the template. Save the small piece, it will be used later.

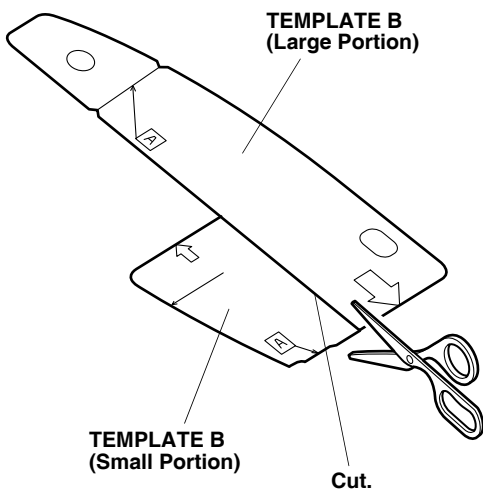

9. Inside the inside of the rear bumper on the left side, locate and remove the bolt and the clip shown.

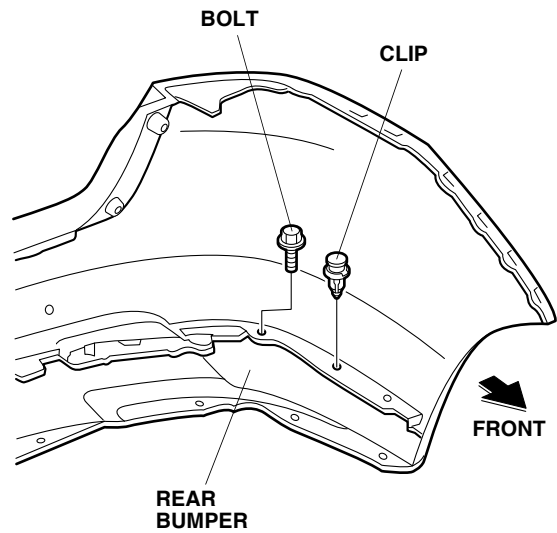

10. Tape template B (large portion) to the bumpers and align the hole in the template with bolt and clip hole.

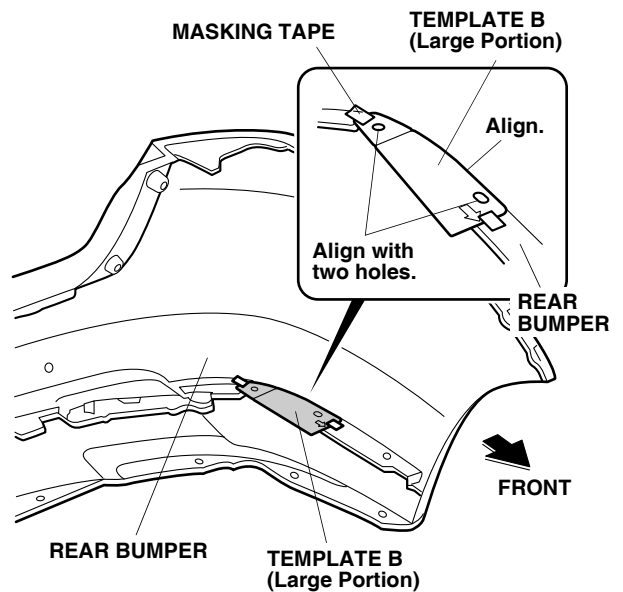

11. Mark the inside edge of the bumper:

- Get the small portion of template B, cut in step 8.
- Stand the small portion of template B straight up (arrow up) at the line on the large portion of template B taped to the bumper.
- Using a felt-tip pen, mark the bumper at the mark indicated on the template.
- Remove both templates.
- Reinstall the bolt and the clip removed in step 9.

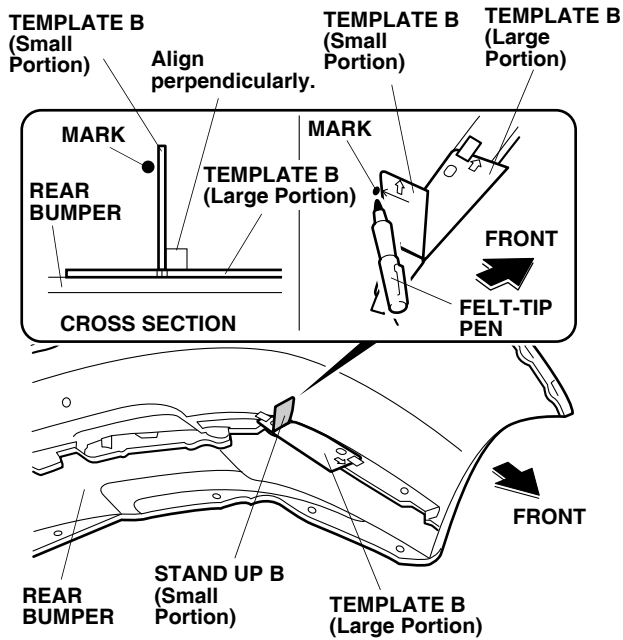

12. Using a pushpin, pierce the bumper at the mark you made on the bumper.

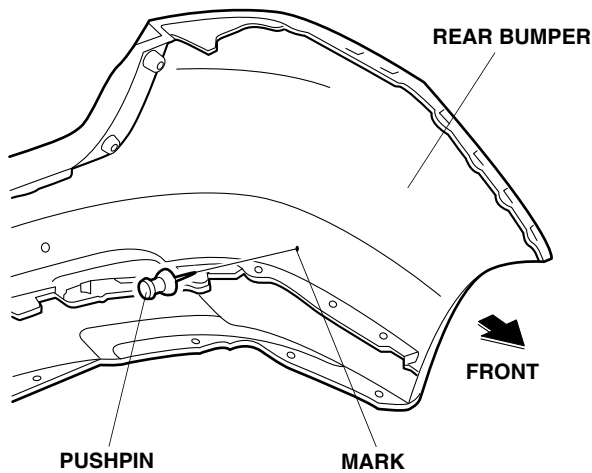

13. While wearing eye protection, drill the bumper:

- From the painted surface of the bumper, drill a 3 mm hole at the pierced mark.
- Using a 12 mm hole saw, enlarge the 3 mm hole to 12 mm.
- Remove all burrs.

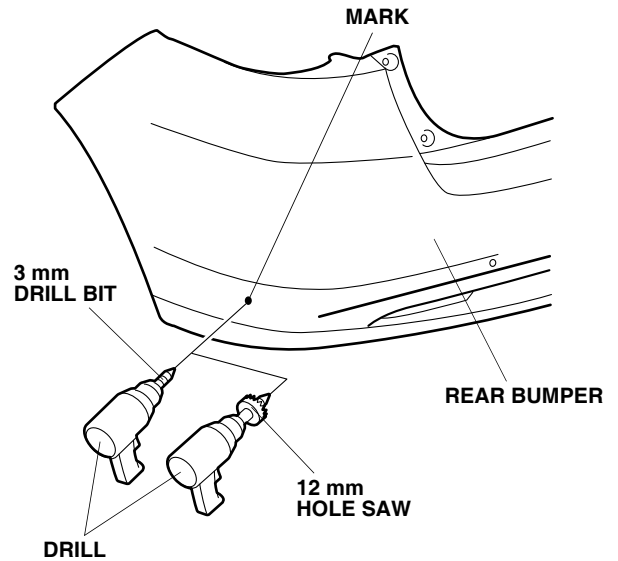

14. On the front edge of the bumper, locate the recess. Using a pushpin, pierce the center of the recess. Install one spring nut over the center of the pierced mark in the direction shown.

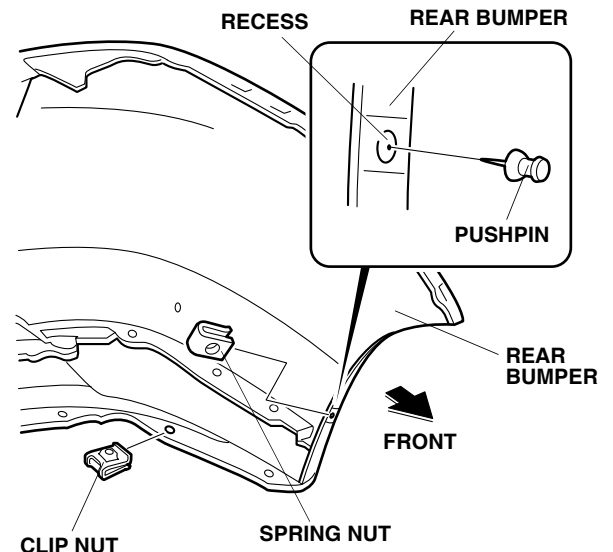

15. Install an additional spring nut over the hole you made in step 7 in the direction shown.
16. Repeat steps 3 thru 15 to mark and drill the right side of the bumper.

17. Using isopropyl alcohol on a shop towel, thoroughly clean the front bumper where the left rear under spoiler will attach. Allow the front bumper to dry.

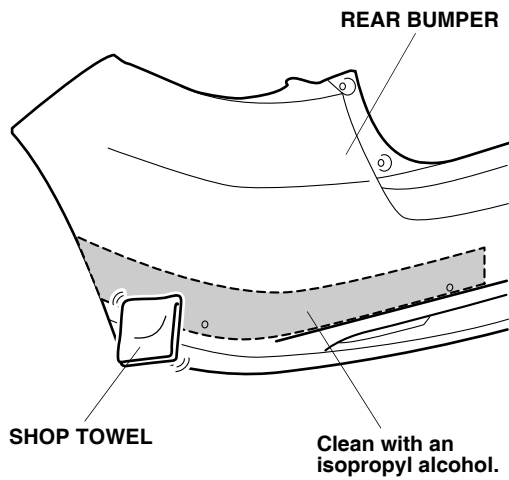

18. Peel back approximately 2 inches of adhesive backing from each adhesive tape, and tape the ends to the front surface of the under spoiler.

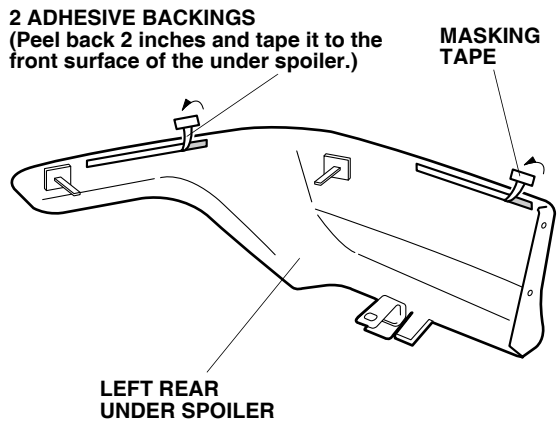

19. Using the seals supplied, build four spacers, two with six seals and two with four seals. Use pieces of masking tape to hold the spacers together.

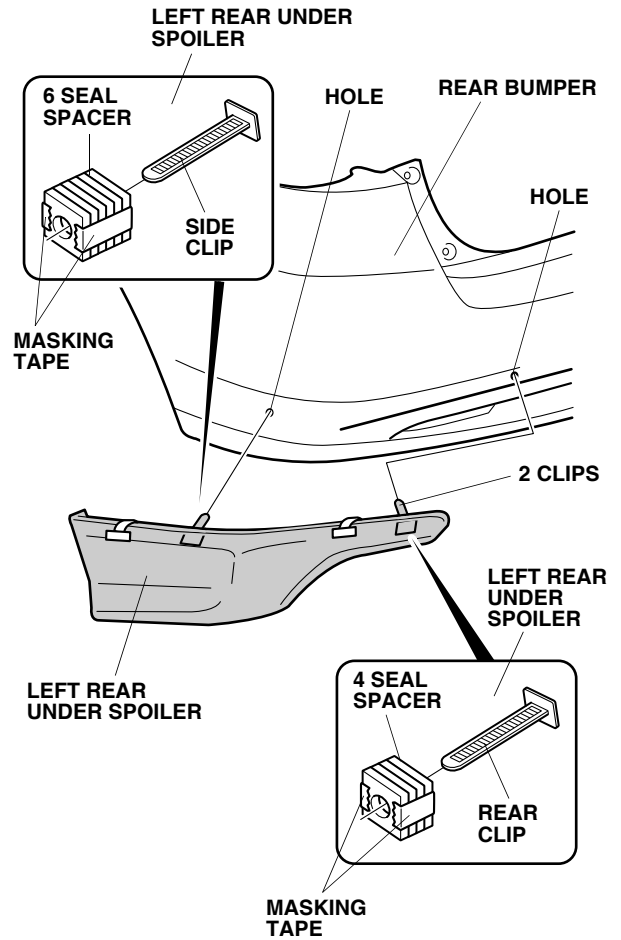

20. Install one six seal spacer over the side clip, install the four seal spacer over the rear clip, and install the left under spoiler to the bumper.

21. Inside the bumper, loosely install a retainer over each clip.

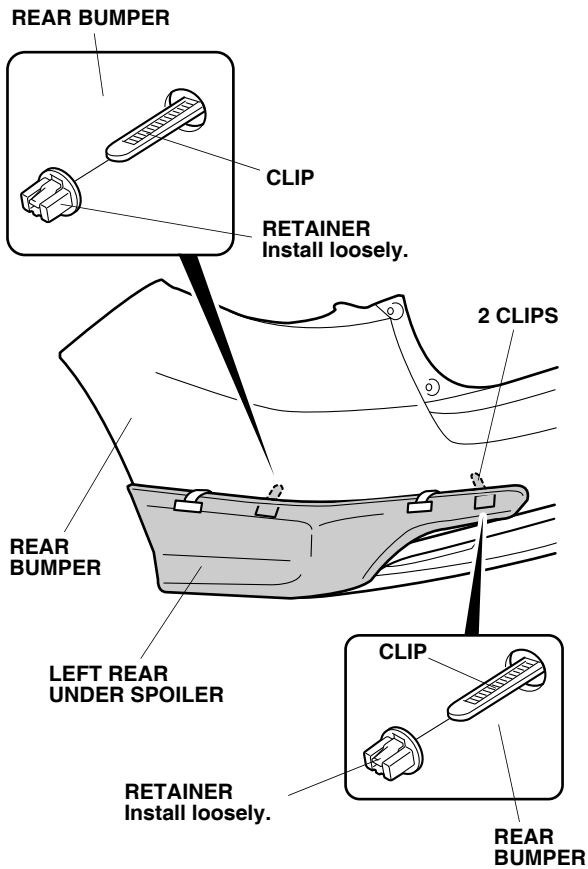

22. Repeat steps 17 thru 21 to clean and loosely install the right under spoiler.
23. Loosely install the two self-tapping screws and one flange bolt to install each spoiler to the bumper.

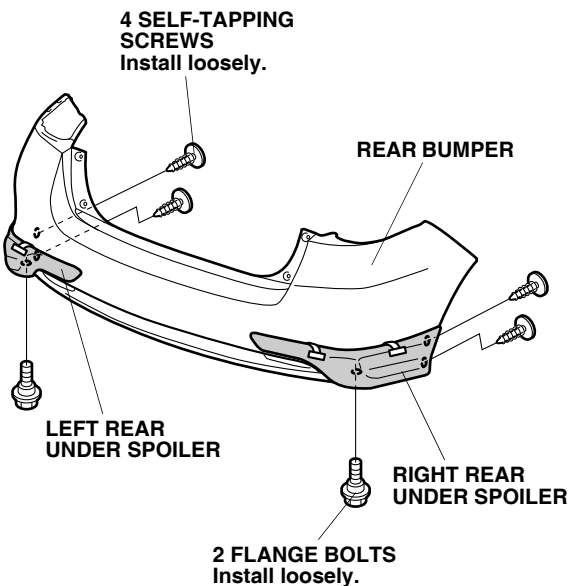

24. While applying light pressure against the left rear under spoiler, carefully remove the taped adhesive backings in the order shown.

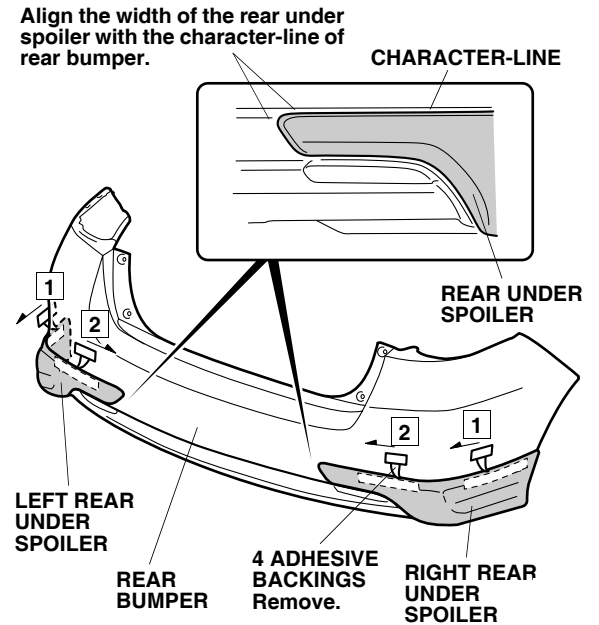

25. Using the palm of your hand, firmly press the left rear under spoiler against the rear bumper. Make sure the width of the rear under spoiler and character line on the rear bumper is the same across the entire spoiler length. If not, realign as necessary.
26. Using a rubber roller, apply pressure against the left rear under spoiler and roll from one end to the other.

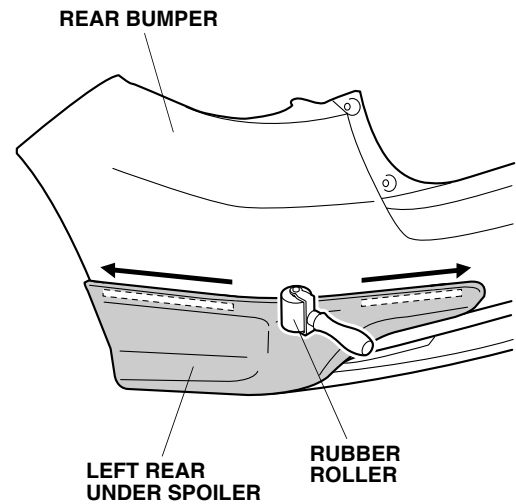

27. Repeat step 24 thru 26 to install the right rear under spoiler.

28. On each side, secure the rear under spoilers with the two retainers.

Do not push the retainers too tight, or it may deform the rear under spoiler. Re-tighten the retainers as necessary, to adjust tightness.

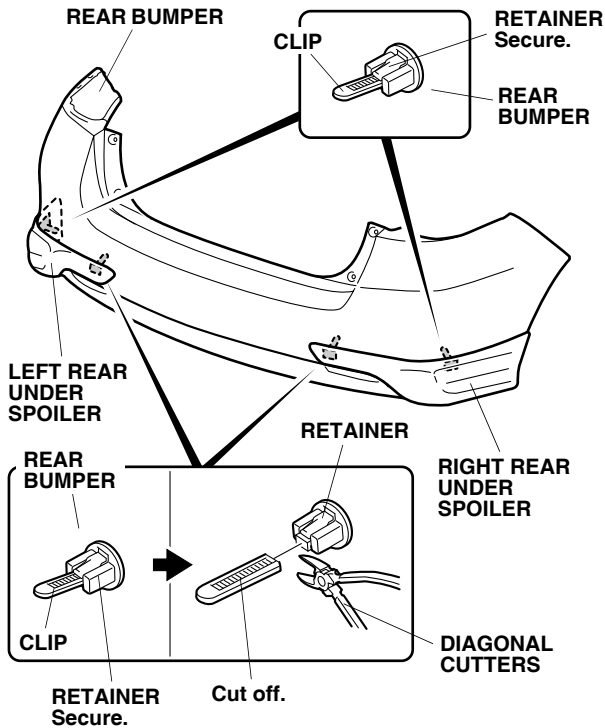

29. Using diagonal cutters, cut off and remove the excess clip end.

30. With the help of an assistant, reinstall the rear bumper.

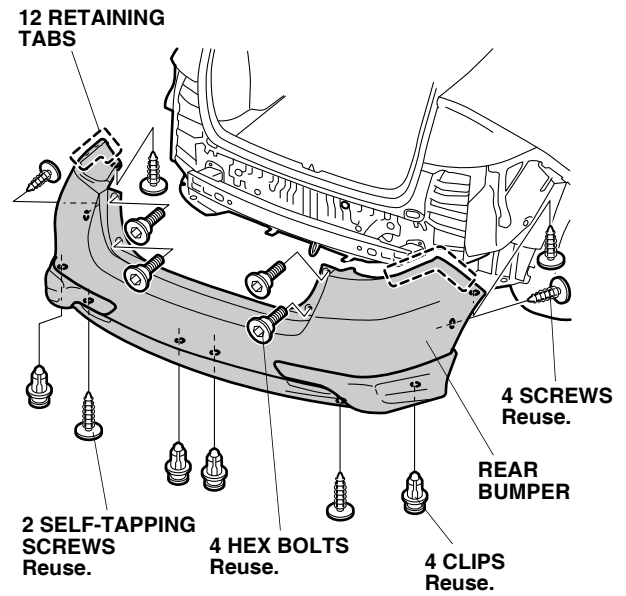

31. Tighten the four self-tapping screws and the two flange bolts you loosely installed secured in step 23.